

7

# BERA ÇALIŞMA MASASI KURULUM ŞEMASI ASSEMBLY GUIDE

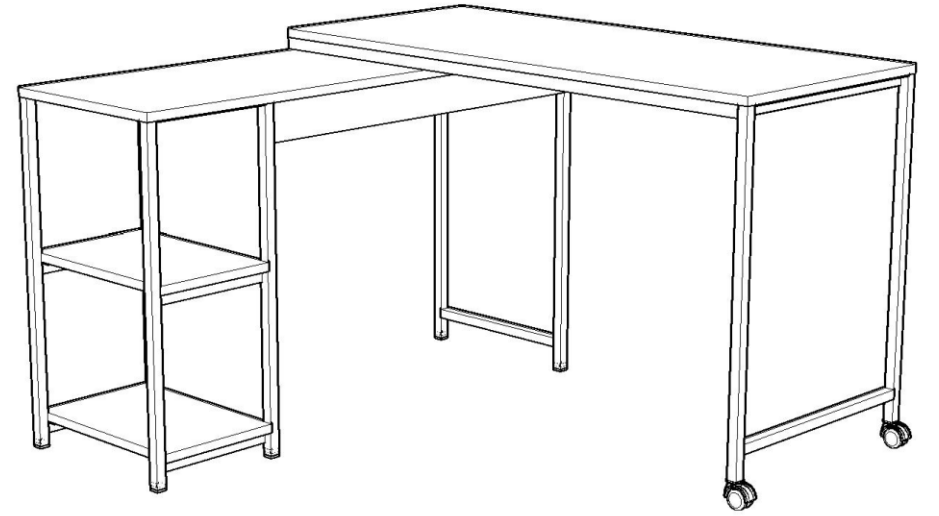

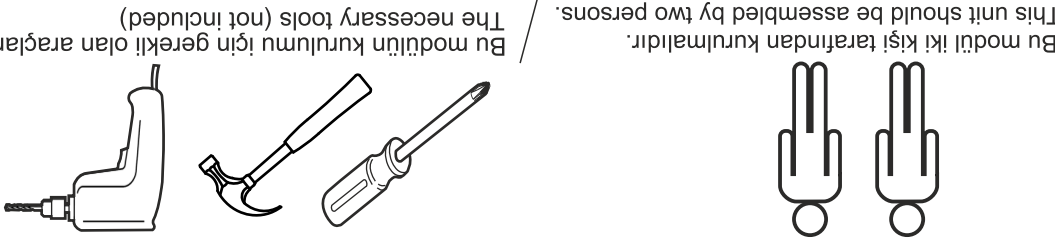







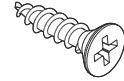

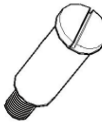
1

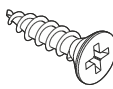

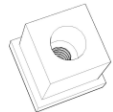
Bu modül iki kişi tarafından kurulmalıdır. / This unit should be assembled by two persons.  
 Bu modülün kurulumu için gerekli olan araçlar. / The necessary tools (not included)

**AKSESUAR LİSTESİ / ACCESSORY LIST**

				3,5 x 18 VİDA x 8 (3,5 x 18 SCREW)
	20x20			MEKANİZMA X 1 TK. (MECHANISM)
				GEKTİRME VİDASI x 17 (PULLING SCREW)
m8 ROTİL X 2 (m8 ROLLER)	TEKERLEK X 2 (WHEEL)	DÜBEL X 17 (PEG)	KARE GEÇME TAPA x 6 (COVER)	MEKANİZMA VİDASI X 1 (MECHANISM SCREW)
				3,5 x 50 VİDA x 3 (3,5 x 50 SCREW)

\* AKSESUARLARI GÖSTERİLDİĞİ GİBİ DÜZ BİR ZEMİN ÜZERİNDE TAKINIZ...  
 \* ÜRÜNÜ KURARKEN MONTAJ SIRASINI TAKİP EDİNİZ  
 \* FİX THE ACCESSORIES AS SHOWN FOLLOW THE  
 INSTALLATION SEQUENCE WHILE INSTALLING THE PRODUCT.

9

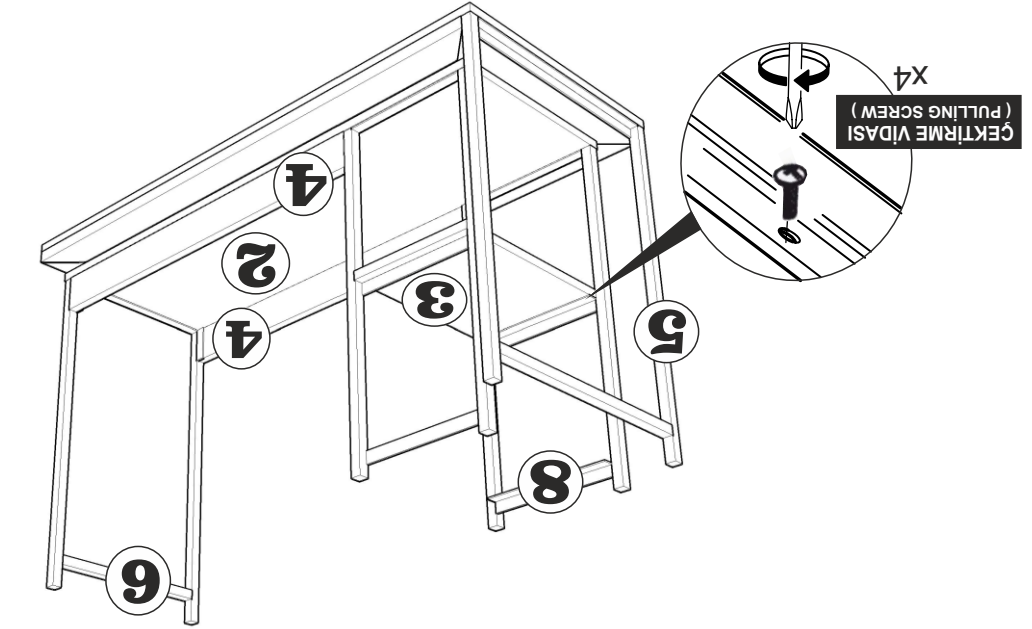
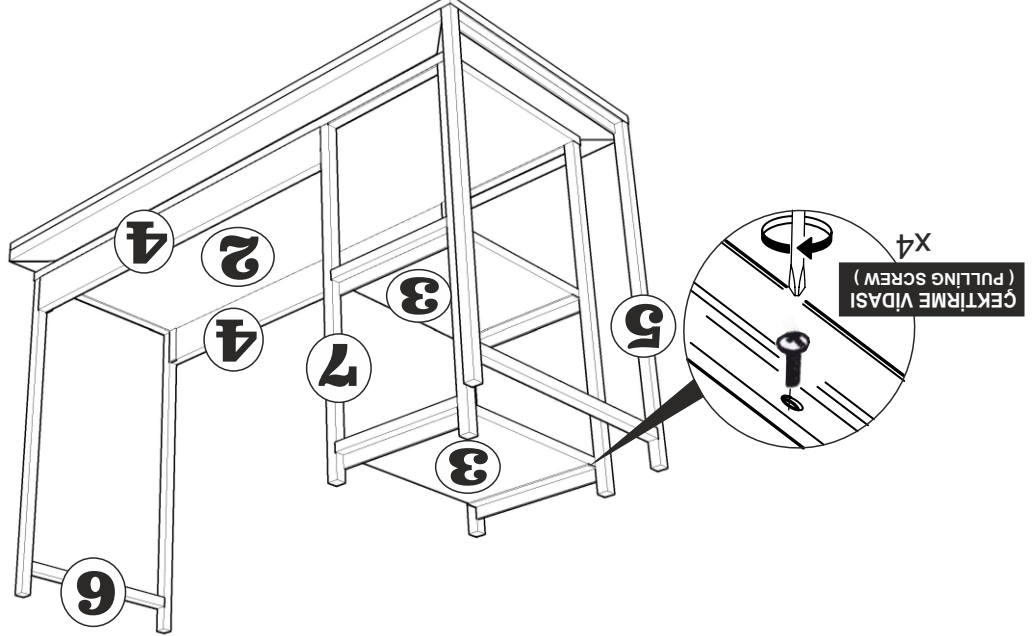

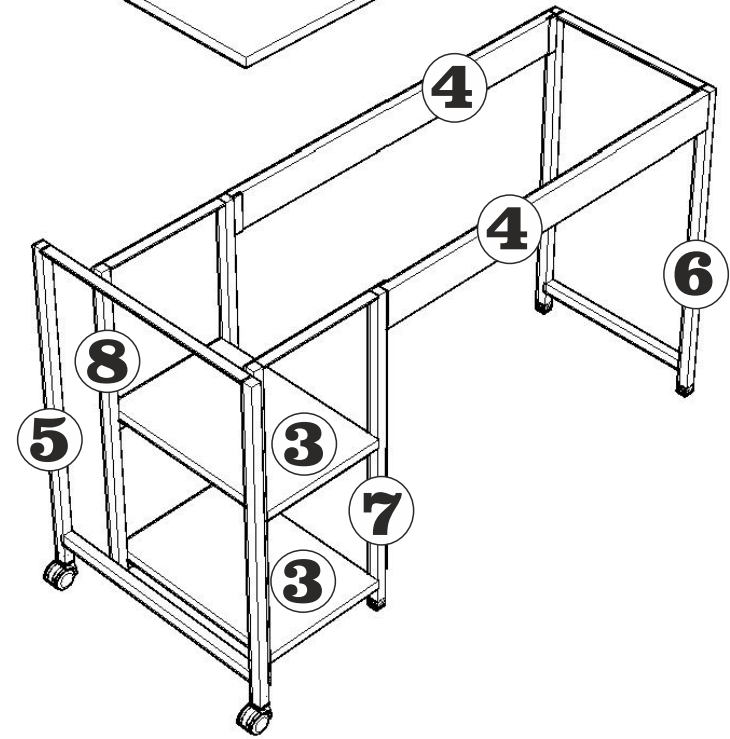
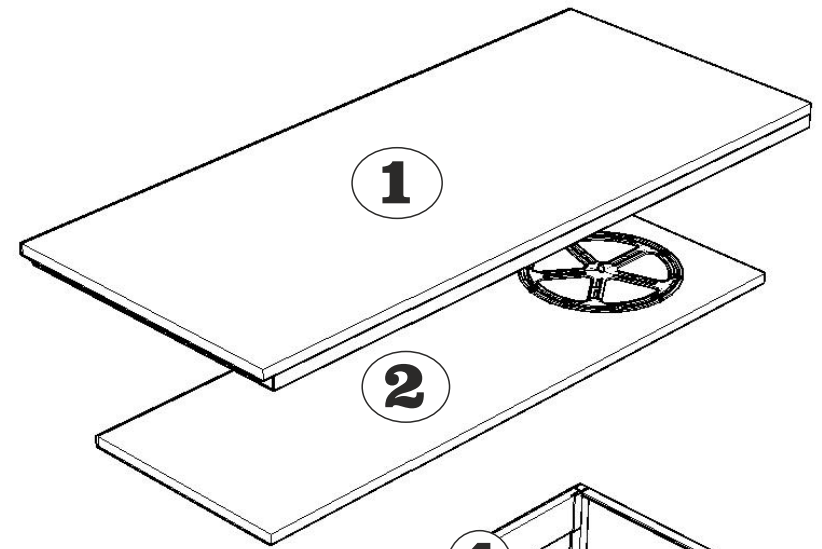
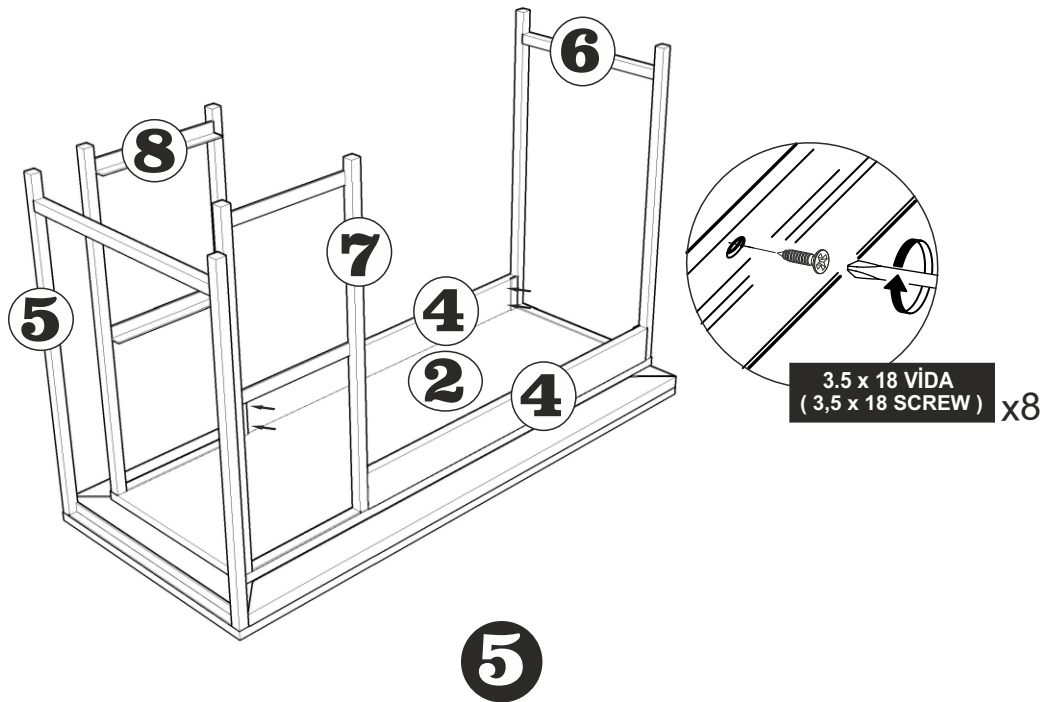
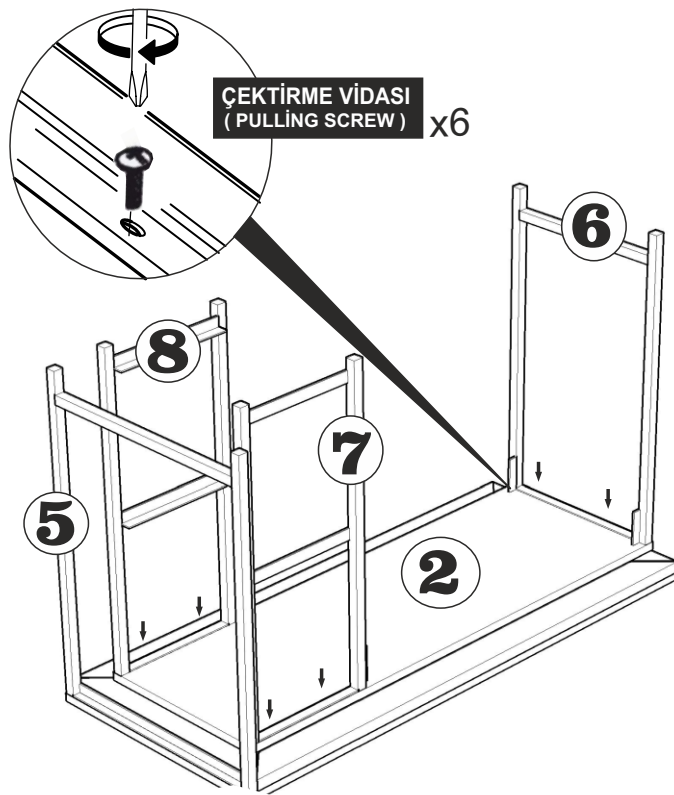

2

4

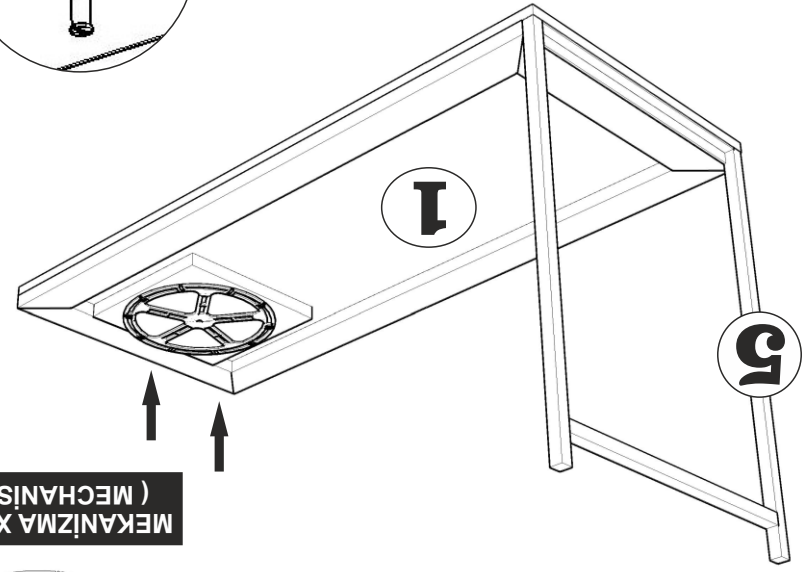
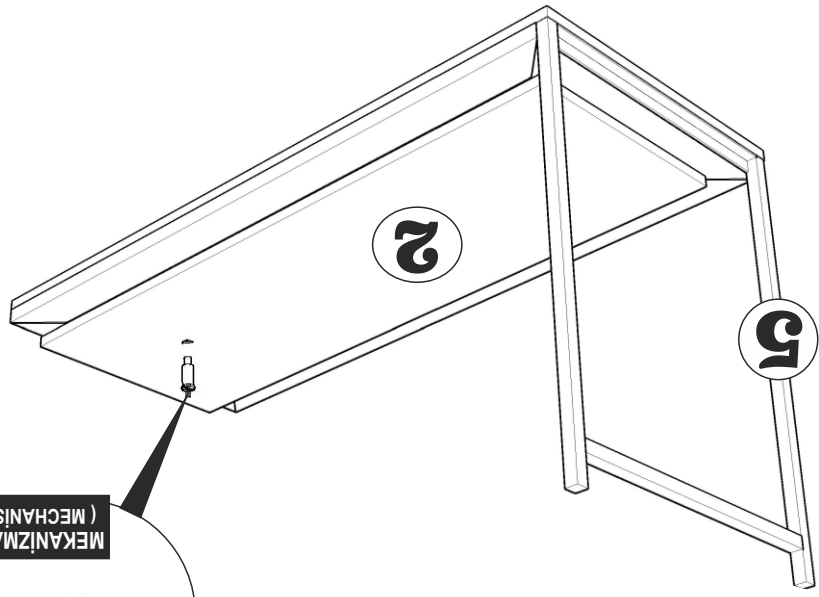

3

